

AXF15-192-80 80KM XFP Optical Transceiver

Features

- ✧ XFP MSA Compliant
- ✧ data rate from 9.95 Gbps to 11.1Gbps
- ✧ No Reference Clock required
- ✧ Cold Start up Wavelength Compliance
- ✧ EML transmitter and APD receiver
- ✧ link length up to 80km
- ✧ Low Power Dissipation 3.5W Maximum
- ✧ -5°C to 70°C Operating Case Temperature
- ✧ Diagnostic Performance Monitoring of module temperature, supply
 - Voltages, laser bias current, transmit optical power, receive optical power
- ✧ RoHS compliant and lead free



Applications

- ✧ SONET OC-192&SDH STM 64
- ✧ 10G Ethernet
- ✧ 80 km 10G Fibre Channel

Description

XFP Transceiver is designed for 10G SDH, 10G ZR and 10G Fibre- Channel applications. The transceiver consists of two sections: The transmitter section incorporates a colded EML laser. And the receiver section consists of a APD photodiode integrated with a TIA. All modules satisfy class I laser safety requirements. XFP transceiver provides an enhanced monitoring interface, which allows real-time access to device operating parameters such as transceiver temperature, laser bias current, transmitted optical power, received optical power and transceiver supply voltage.

Absolute Maximum Ratings

Parameter	Symbol	Min	Max	Unit
Supply Voltage 1	Vcc3	-0.5	4.0	V
Supply Voltage 2	Vcc5	-0.5	6.0	V
Supply Voltage 3	Vcc2		2	
Storage Temperature	Tst	-40	85	°C
Case Operating Temperature	Top	-5	70	°C
Optical Input Received Power	APD-IN	-	-8	dBm

Operating Conditions

Parameter	Symbol	Min	Typical	Max	Unit
Supply Voltage 1	Vcc3	3.13	3.3	3.47	V
Supply current 1	Icc3			750	mA
Supply Voltage 2	Vcc5	4.75	5	5.25	V
Supply current 2	Icc5			500	mA
Supply Voltage 3	Vcc2	1.71	1.8	1.89	V
Supply current 3	Icc2			750	mA
Operating Case temperature	Tca	-5	-	70	°C
Module Power Dissipation	Pm	-		3.5	W

Transmitter Specifications – Optical

Parameter	Symbol	Min	Typical	Max	Unit
Data Rate Multirate	Mra	9.95	-	11.1	Gbps
Center Wavelength	λ_c		1550		nm
Optical Transmit Power	Po	0	-	+4	dBm
Optical Transmit Power (disabled)	PTX_DISABLE	-	-	-30	dBm
Extinction Ratio	ER	8.2		-	dB
Channel Spacing	Δf	-	100	-	GHz
Jitter Generation	TJP-P	-	-	0.1	UI
Spectral Width (-20dB)	DI20	-	0.1	0.3	nm
Side Mode Suppression Ratio	SMSR	30	-	-	dB
Dispersion penalty(800ps/nm)	DP			2	dB
Eye Mask	Compliant with ITU-T G.691 STM-64 eye mask				

Transmitter Specifications – Electrical

Parameter	Symbol	Min	Typical	Max	Unit
Input differential impedance	Rim	-	100	-	Ω
Differential data Input	VtxDIFF	120	-	850	mV
Transmit Disable Voltage	VD	2.0	-	Vcc3+0.3	V
Transmit Enable Voltage	Ven	0	-	+0.8	V
Transmit Disable Assert Time	Vn	-	-	10	us

Receiver Specifications – Optical

Parameter	Symbol	Min	Typical	Max	Unit
Data Rate Multirate	Mra	9.95	-	11.1	Gbps
Receiver Sensitivity 9.95Gb/s	Rsens9	-	-	-24	dBm
Receiver Sensitivity 10.7Gb/s	Rsens10	-	-	-23	dBm
Maximum Input Power	RX-overload	-	-	-7	dBm
Input Operating Wavelength	λ	1528	-	1564	nm
Reflectance	Rrx	-	-	-27	dB
Loss of Signal Asserted		-34	-	-	dBm
LOS De-Asserted		-	-	-24	dBm
LOS Hysteresis		0.5	-	-	dB

Receiver Specifications – Electrical

Parameter	Symbol	Min	Typical	Max	Unit
Differential Output Swing	Vout P-P	350	-	850	mV
Rise/Fall Time	Tr / Tf	24	-	-	ps
Loss of Signal –Asserted	VOH	2	-	Vcc3+0.3-	V
Loss of Signal –Negated	VOL	0	-	+0.4	V

Low Speed Electrical Signal Timings

Parameter	Symbol	Min	Typical	Max	Unit
TX Disable, Power_Down/RST	VIH	2.0		Vcc3+0.3	V
	VIL	-0.3		0.8	V
Interrupt, Mod_NR, Rx_Los	VOH	Vdd3-0.5		Vdd3+0.3	V
	VOL	0		0.4	V
SCL,SDA(IN)	VIH	Vdd3*0.7		Vdd3+0.5	V
	VIL	-0.3		Vdd3*0.3	V
SCL,SDA(OUT)	VOH	Vdd3-0.5		Vdd3+0.3	V
	VOL	0		0.4	V
I2C clock rate	t_reset		-	400	KHz
Leakage current	IL	-	-	100	uA

Pin Descriptions

Pin	Logic	Symbol	Name/Description	Ref.
1		GND	Module Ground	1
2		VEE5	Optional -5.2 Power Supply – Not required	

3	LVTTTL-I	Mod-Desel	Module De-select; When held low allows the module to , respond to 2-wire serial interface commands	
4	LVTTTL-O	Interrupt	Interrupt (bar); Indicates presence of an important condition which can be read over the serial 2-wire interface	2
5	LVTTTL-I	TX_DIS	Transmitter Disable; Transmitter laser source turned off	
6		VCC5	+5 Power Supply	
7		GND	Module Ground	1
8		VCC3	+3.3V Power Supply	
9		VCC3	+3.3V Power Supply	
10	LVTTTL-I	SCL	Serial 2-wire interface clock	2
11	LVTTTL- I/O	SDA	Serial 2-wire interface data line	2
12	LVTTTL-O	Mod_Abs	Module Absent; Indicates module is not present. Grounded in the module.	2
13	LVTTTL-O	Mod_NR	Module Not Ready;	2
14	LVTTTL-O	RX_LOS	Receiver Loss of Signal indicator	2
15		GND	Module Ground	1
16		GND	Module Ground	1
17	CML-O	RD-	Receiver inverted data output	
18	CML-O	RD+	Receiver non-inverted data output	
19		GND	Module Ground	1
20		VCC2	+1.8V Power Supply	
21	LVTTTL-I	P_Down/RS T	Power Down; When high, places the module in the low power stand-by mode and on the falling edge of P_Down initiates a module reset	
			Reset; The falling edge initiates a complete reset of the module including the 2-wire serial interface, equivalent to a power cycle.	
22		VCC2	+1.8V Power Supply	
23		GND	Module Ground	1
24	PECL-I	RefCLK+	Reference Clock non-inverted input, AC coupled on the host board – Not required	3
25	PECL-I	RefCLK-	Reference Clock inverted input, AC coupled on the host board – Not required	3
26		GND	Module Ground	1
27		GND	Module Ground	1
28	CML-I	TD-	Transmitter inverted data input	
29	CML-I	TD+	Transmitter non-inverted data input	
30		GND	Module Ground	1

Notes:

1. Module circuit ground is isolated from module chassis ground within the module.
2. Open collector; should be pulled up with 4.7k – 10k ohms on host board to a voltage between 3.15V and 3.6V.
3. A Reference Clock input is not required.

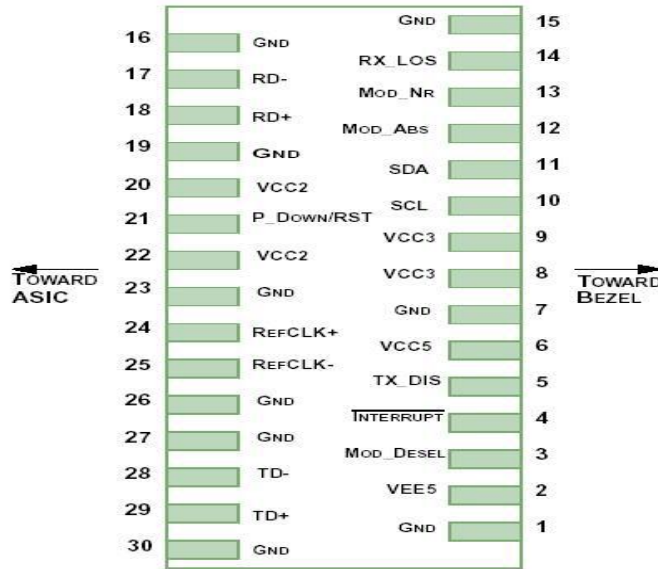

Figure1.Electrical Pin-out Details

Digital Diagnostic Functions

AXF15-192-80 Small Form Factor 10Gb/s (XFP) transceivers are compliant with the current XFP Multi-Source Agreement (MSA) Specification Rev 4.5.

As defined by the XFP MSA, XFP transceivers provide digital diagnostic functions via a 2-wire serial interface, which allows real-time access to the following operating parameters:

- ◆ Transceiver temperature
- ◆ Laser bias current
- ◆ Transmitted optical power
- ◆ Received optical power
- ◆ Transceiver supply voltage

It also provides a sophisticated system of alarm and warning flags, which may be used to alert end-users when particular operating parameters are outside of a factory-set normal range.

Figure1.2-wire Serial Digital Diagnostic Memory Map

The operating and diagnostics information is monitored and reported by a Digital Diagnostics Transceiver Controller inside the transceiver, which is accessed through the 2-wire serial interface. When the serial protocol is activated, the serial clock signal (SCL pin) is generated by the host. The positive edge clocks data into the XFP transceiver into those segments of its memory

map that are not write-protected. The negative edge clocks data from the XFP transceiver. The serial data signal (SDA pin) is bi-directional for serial data transfer. The host uses SDA in conjunction with SCL to mark the start and end of serial protocol activation. The memories are organized as a series of 8-bit data words that can be addressed individually or sequentially. The 2-wire serial interface provides sequential or random access to the 8 bit parameters, addressed from 000h to the maximum address of the memory.

EEPROM Serial ID Memory Contents

Data Address	Field Size (Bytes)	Name of Field	Description and Contents
Base ID Fields			
128	1	Identifier	Type of Serial transceiver (06h=XFP)
129	1	Ext. Identifier	TX Ref Clock Input not Required (90h)
130	1	Connector	Code of optical connector type (07h=LC)
131-138	8	Transceiver	10G ZR
139	1	Encoding	NRZ(10h)
140	1	BR-MIN	9.953Gbps(63h)
141	1	BR-MAX	11.3Gbps(71h)
142	1	Length(SMF)-km	80KM(50h)
143	1	Length(E-50um)	(00h)
144	1	Length(50um)	(00h)
145	1	Length(62.5um)	(00h)
146	1	Length(Copper)	(00h)
147	1	Device Tech	Cooled1550nm EML, PIN Detector(74h)
148-163	16	Vendor Name	XFP vendor name: "****" (ASCII)
164	1	CDR Support	CDR supports 9.953Gbps~11.1Gbps(F8h)
165-167	3	Vendor OUI	XFP transceiver vendor OUI ID
168-183	16	Vendor PN	Part Number: "AXF15-192-80" (ASCII)
184-185	2	Vendor rev	"32 61" means 2a revision (ASCII)
186-187	2	Wavelength	Wavelength
188-189	2	Wavelength Tolerance	+/-0.025nm
190	1	Max Case Temp	70°C(46h)
191	1	CC_BASE	Check sum of bytes 128~190
192-195	4	Power Supply	3.5W(MAX) (AF 96 A7 01)
196-211	16	Vendor SN	Serial number (ASCII)
212-219	8	Date code	Year(2 bytes), Month(2 bytes), Day (2 bytes)
220	1	Diagnostic type	No BER Support, Average Power(08h)
221	1	Enhanced option	Optional Soft Tx_Disable and P_Down(60h)
222	1	Aux Monitoring	+5.0V and +3.3V Supply Voltage(67h)
223	1	CC_EXT	Check sum of bytes 192~222
Vendor Specific ID fields			
224-255	32	Vendor specific	Vendor specific

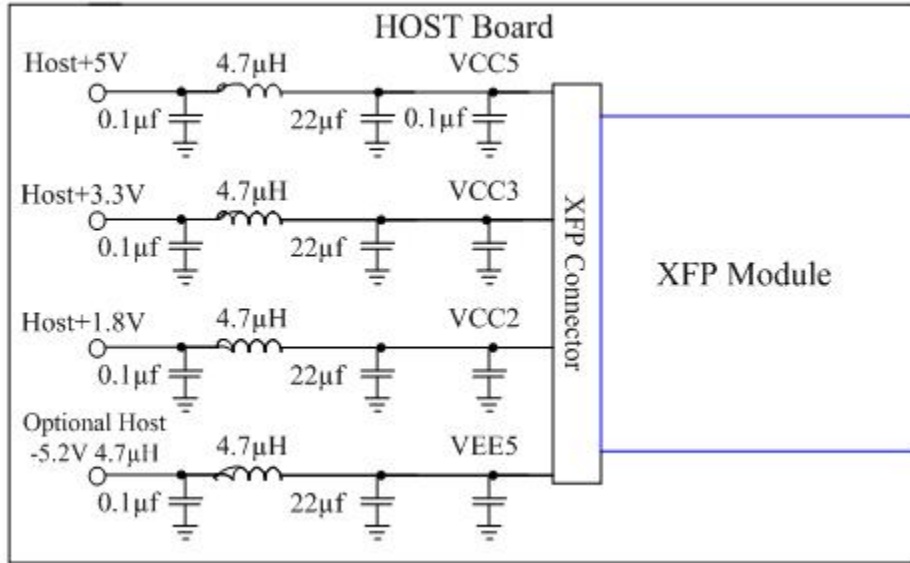

Figure3. Recommended Host Board Power Supply Circuit

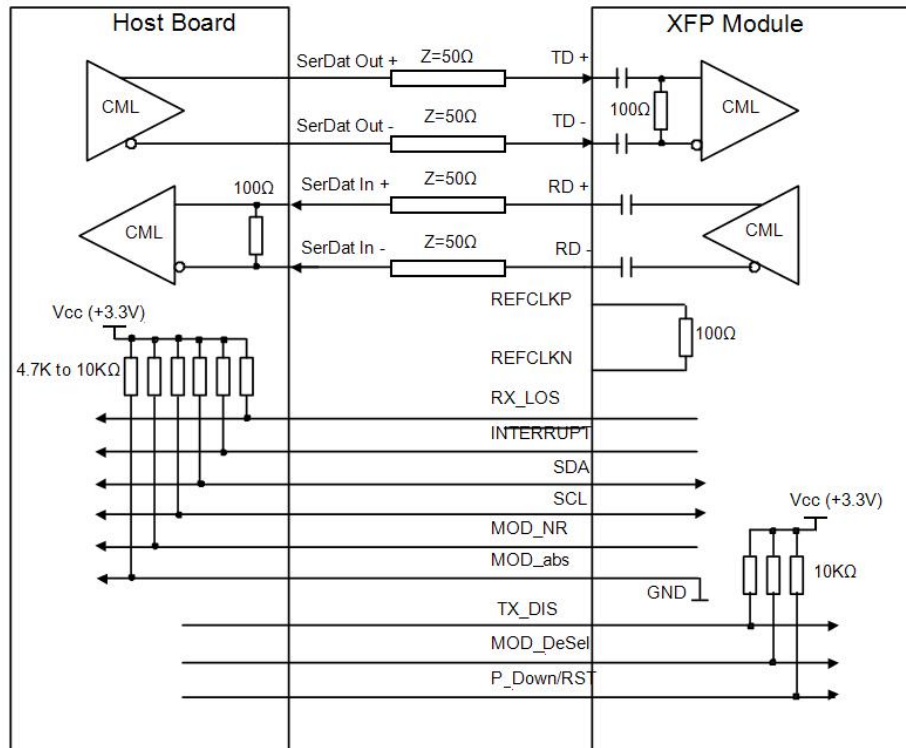

Figure4. Recommended High-speed Interface Circuit

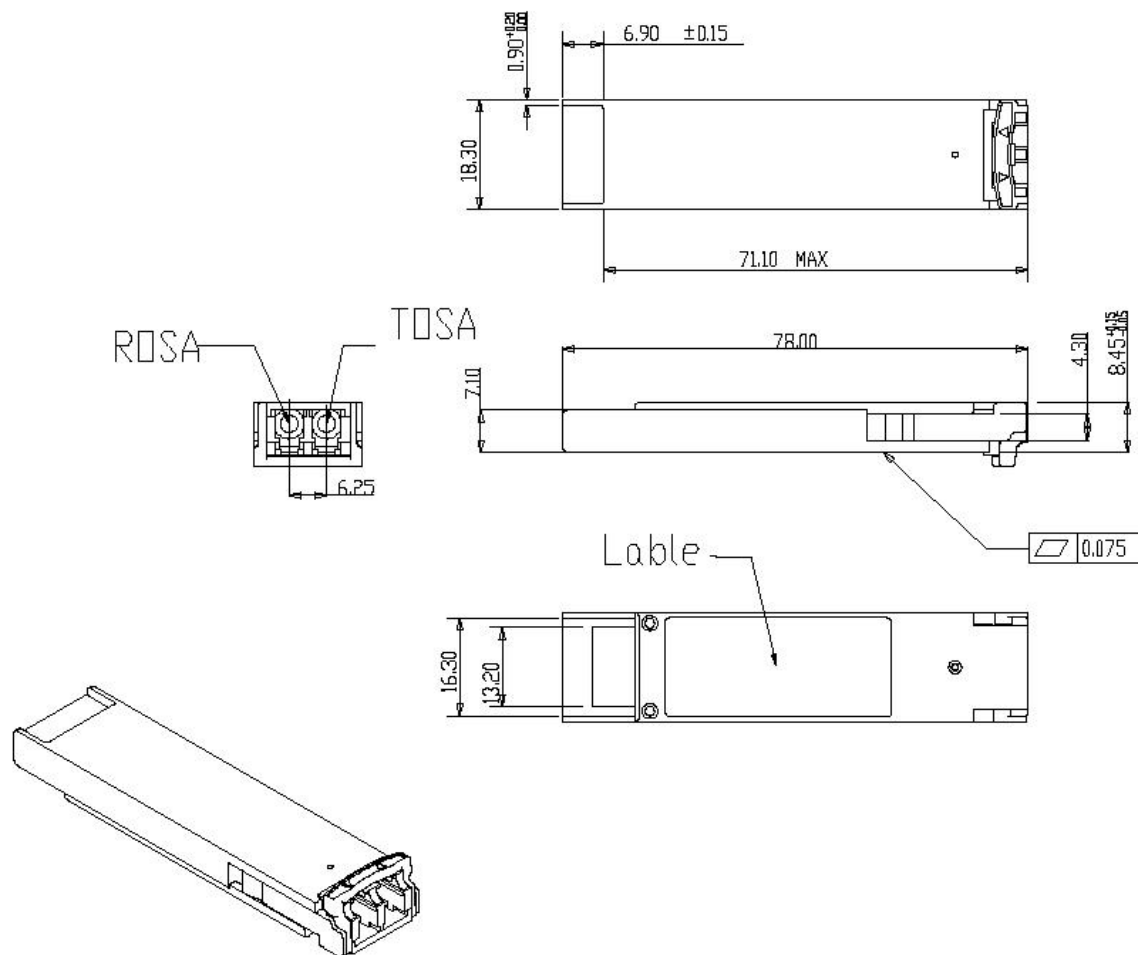

Figure5. Mechanical Specifications

Ordering information

Part Number	Product Description
AXF15-192-80	10Gbps, XFP 80km, -5°C ~ +70°C

Further Information

For further information, please contact info@10gtek.com

Tel : +86 755 2998 8100

Fax: +86 755 6162 4140

Web: www.10gtek.com